

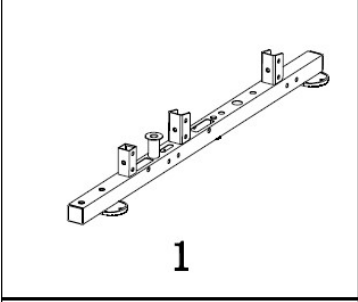

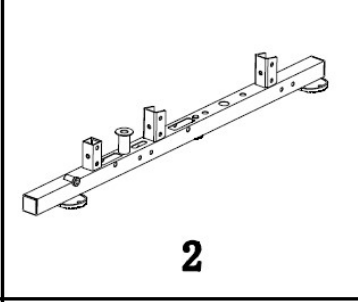

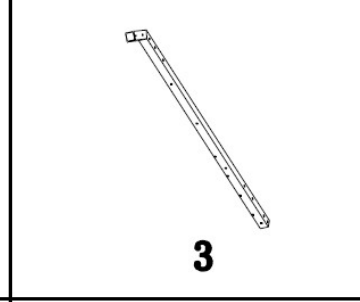

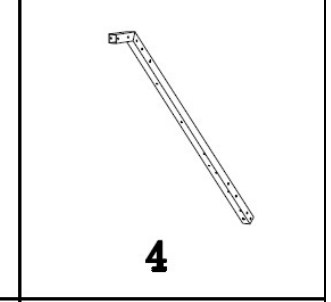

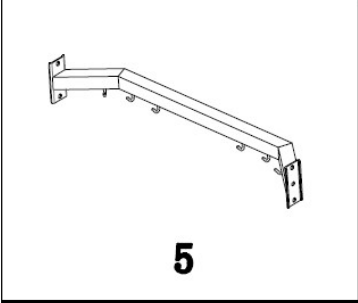
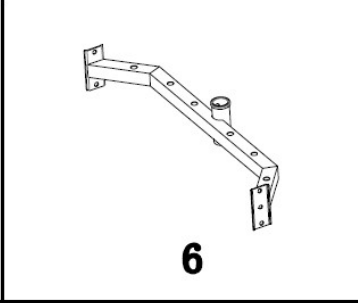
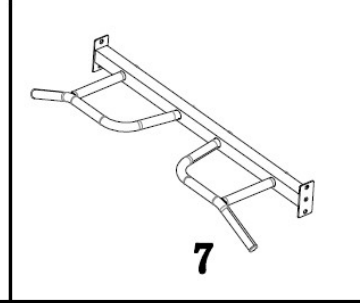
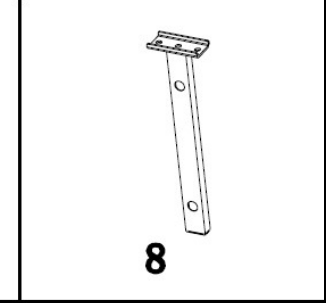
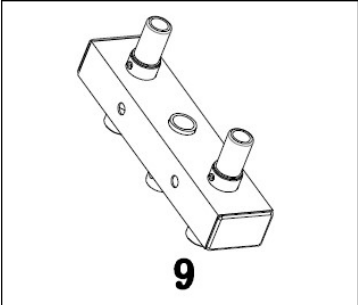
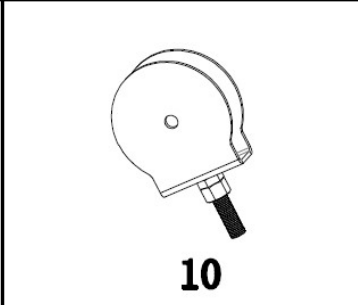
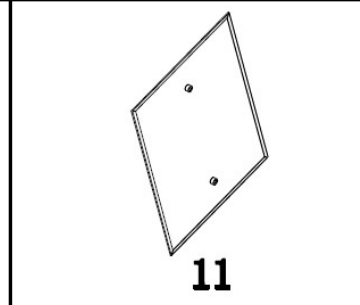
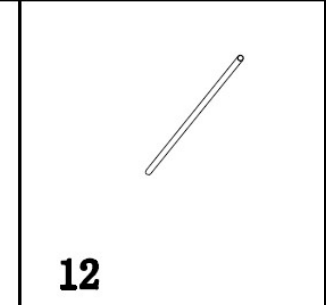
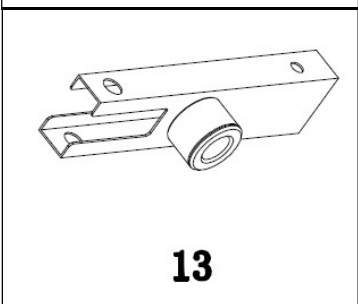
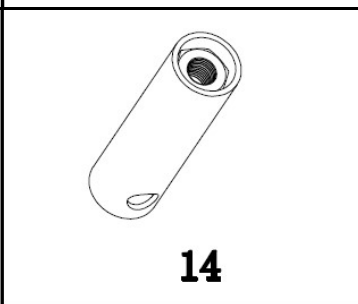
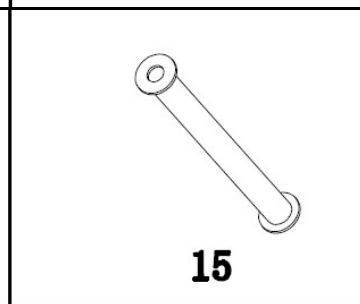
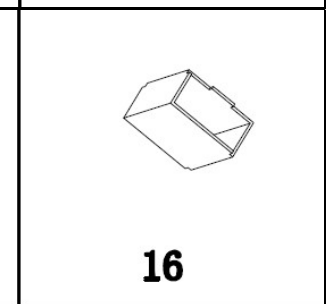
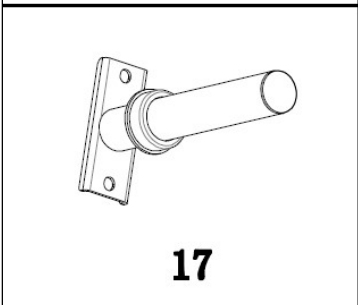
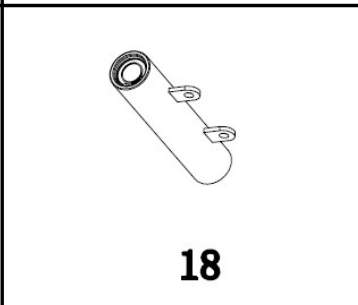
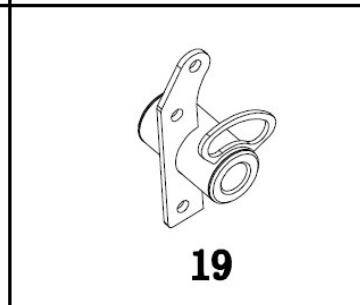
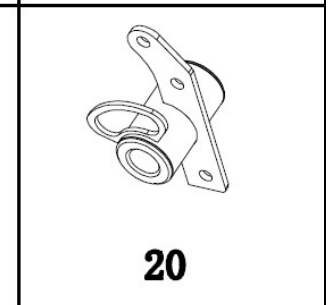
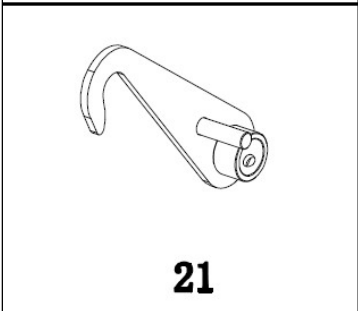
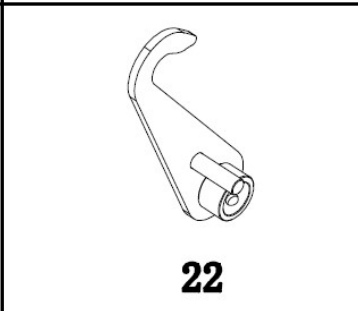
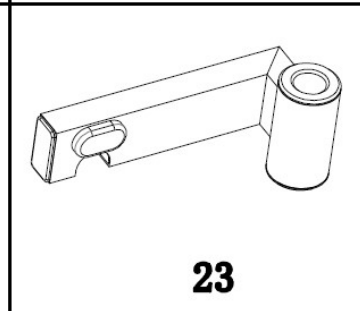
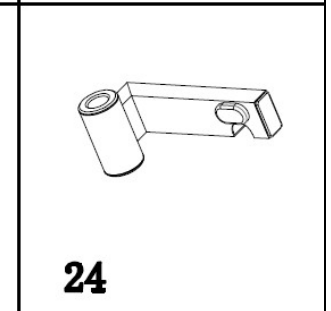

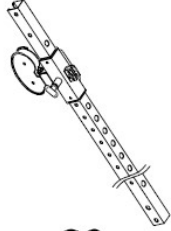
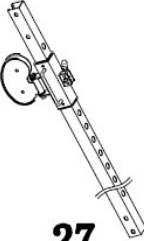
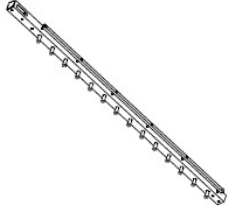



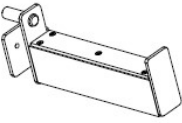
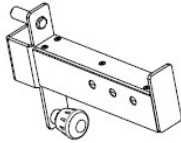
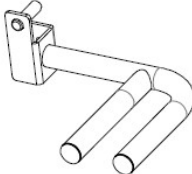
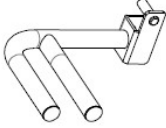
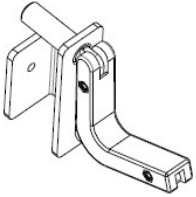
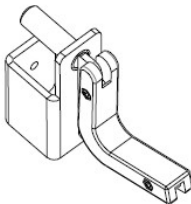
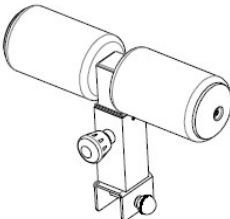
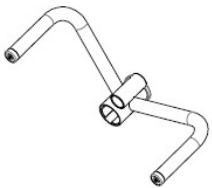
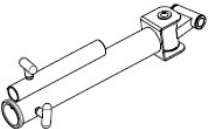

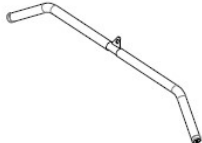

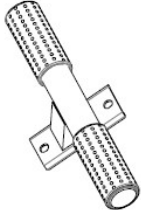

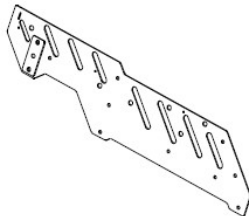
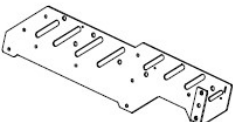

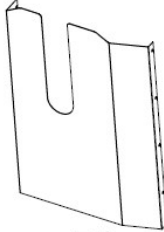
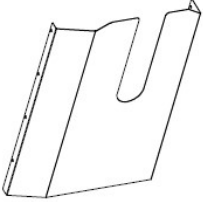
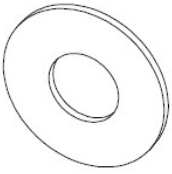
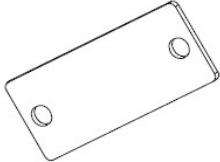
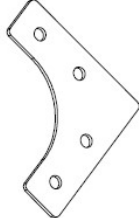
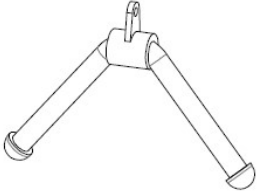



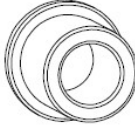
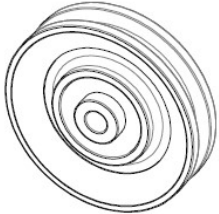
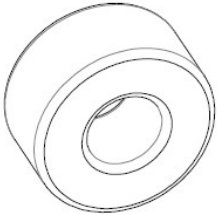

Návod k obsluze

Obr. A

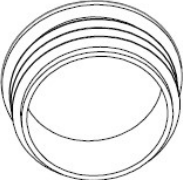
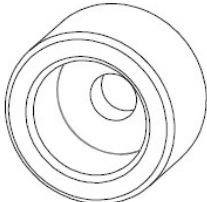
 <p><b>1</b></p>	 <p><b>2</b></p>	 <p><b>3</b></p>	 <p><b>4</b></p>
 <p><b>5</b></p>	 <p><b>6</b></p>	 <p><b>7</b></p>	 <p><b>8</b></p>
 <p><b>9</b></p>	 <p><b>10</b></p>	 <p><b>11</b></p>	 <p><b>12</b></p>
 <p><b>13</b></p>	 <p><b>14</b></p>	 <p><b>15</b></p>	 <p><b>16</b></p>
 <p><b>17</b></p>	 <p><b>18</b></p>	 <p><b>19</b></p>	 <p><b>20</b></p>
 <p><b>21</b></p>	 <p><b>22</b></p>	 <p><b>23</b></p>	 <p><b>24</b></p>

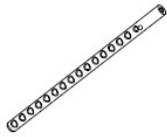
 <p><b>25</b></p>	 <p><b>26</b></p>	 <p><b>27</b></p>	 <p><b>28</b></p>
 <p><b>29</b></p>	 <p><b>30</b></p>	 <p><b>31</b></p>	 <p><b>32</b></p>
 <p><b>33</b></p>	 <p><b>34</b></p>	 <p><b>35</b></p>	 <p><b>36</b></p>
 <p><b>37</b></p>	 <p><b>38</b></p>	 <p><b>39</b></p>	 <p><b>40</b></p>
 <p><b>41</b></p>	 <p><b>42</b></p>	 <p><b>43</b></p>	 <p><b>44</b></p>
 <p><b>45</b></p>	 <p><b>46</b></p>	 <p><b>47</b></p>	 <p><b>48</b></p>

 <p><b>49</b></p>	 <p><b>50</b></p>	 <p><b>51</b></p>	 <p><b>52</b></p>	
 <p><b>53</b></p>	 <p><b>54</b></p>	 <p><b>55</b></p>	 <p><b>56</b></p>	
 <p><b>57</b></p>	 <p><b>58</b></p>	 <p><b>59</b></p>	 <p><b>60</b></p>	
 <p><b>61</b></p>	 <p><b>62</b></p>	 <p><b>63</b></p>	 <p><b>64</b></p>	
 <p><b>65</b></p>	 <p><b>66</b></p>	 <p><b>67</b></p>	 <p><b>68</b></p>	
 <p><b>69</b></p>	 <p><b>70</b></p>	<p><b>G145</b></p>		
		 <p><b>96</b></p>	 <p><b>97</b></p>	 <p><b>98</b></p>

# HARDWARE PACK(4-1)



#71 M8X25 Button Head Cap Screw (pcs-2)

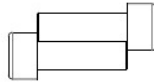

#77 M8X25 Socket Head Cap Screw(pcs2)

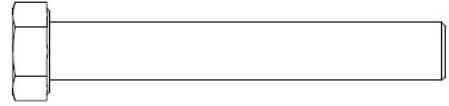

#75 M16X110 Button Head Cap Screw (pcs1)



#72 M10X30 Button Head Cap Screw (pcs2)

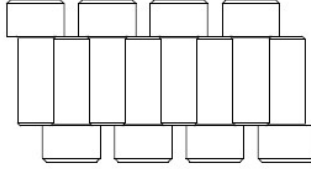

#78 M10X25 Socket Head Cap Screw(pcs8)

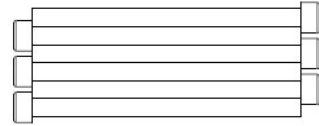

#76 M5X75 Socket Head Cap Screw(pcs6)

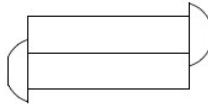

#73 M10X45 Button Head Cap Screw (pcs2)

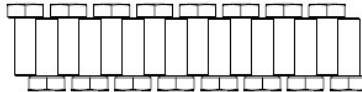

#79 M6X16 Hex Head Bolt (pcs16)



#92 M5 Nylon Lock Nut(pcs6)

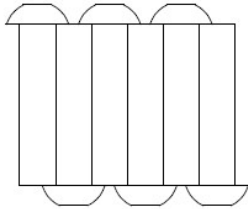

#74 M10X45 Button Head Cap Screw (pcs6)

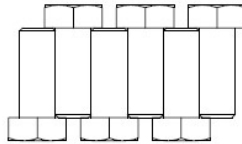

#80 M10X25 Hex Head Bolt (pcs6)



#81 M10X80 Hex Head Bolt (pcs4)

# HARDWARE PACK(4-2)

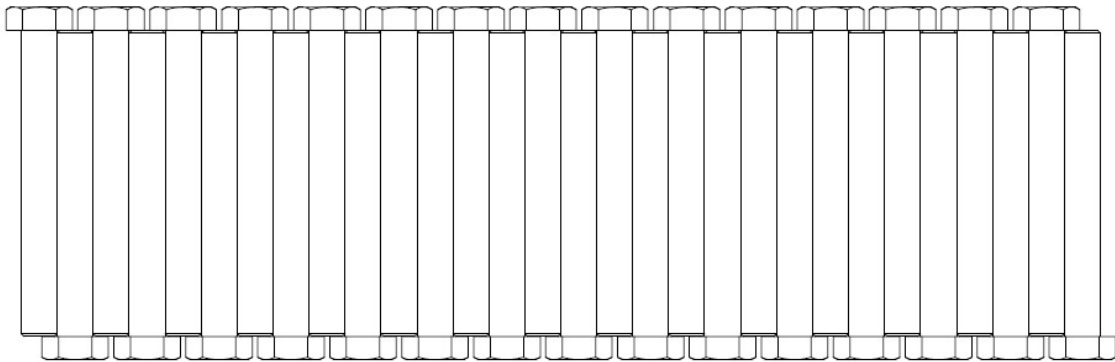

#82 M10X85 Hex Head Bolt (pcs30)

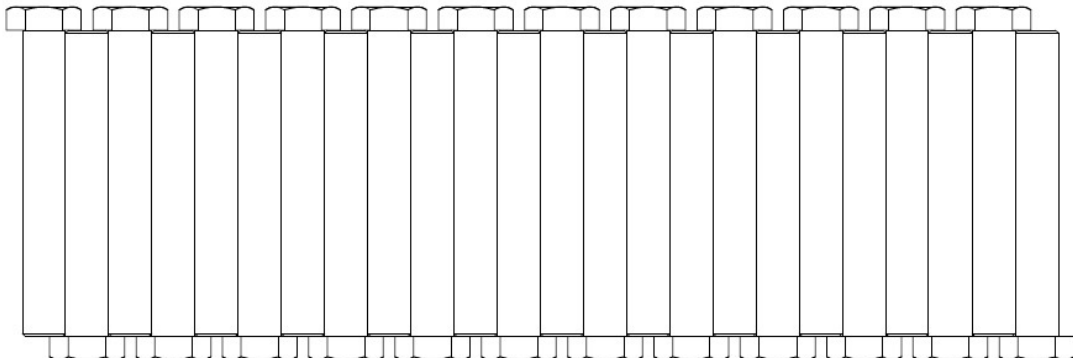

#85 M12X85 Hex Head Bolt (pcs24)

# HARDWARE PACK(4-3)



#88  $\phi 8.5 \times \phi 16 \times 1.5$  Flat Washer (pcs2)

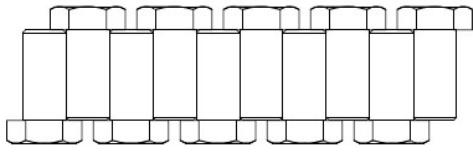

#83 M12X25 Hex Head Bolt (pcs10)

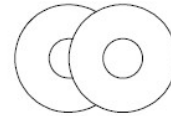

#95  $\phi 11 \times \phi 30 \times 2.5$  Flat Washer (2pcs)



#84 M12X65 Hex Head Bolt (pcs4)

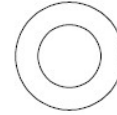

#91  $\phi 30 \times \phi 17.5 \times 3$  Flat Washer (pcs1)



#86 M12X90 Hex Head Bolt (pcs4)



#87 M12X100 Hex Head Bolt (pcs4)

# HARDWARE PACK(4-4)

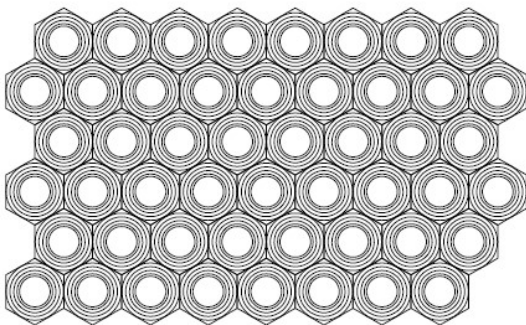

#93 M10 Nylon Lock Nut (pcs50)

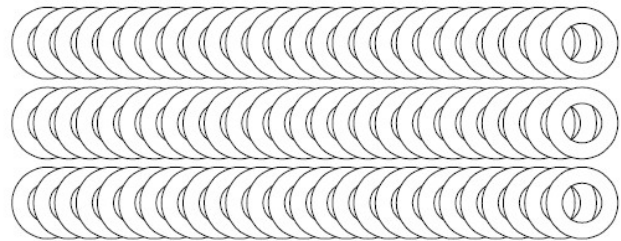

#89  $\phi 11 \times \phi 20 \times 2$  Flat Washer (pcs78)

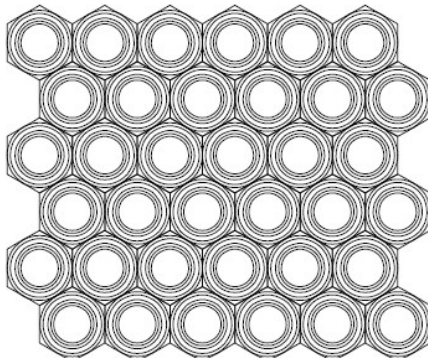

#94 M12 Nylon Lock Nut (pcs36)

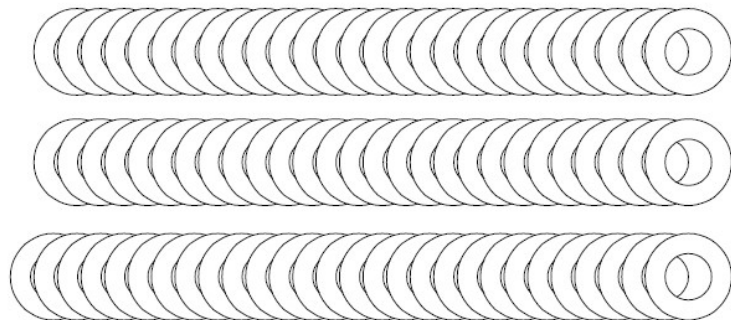

#90  $\phi 13 \times \phi 24 \times 2$  Flat Washer (pcs82)

Obr. 1

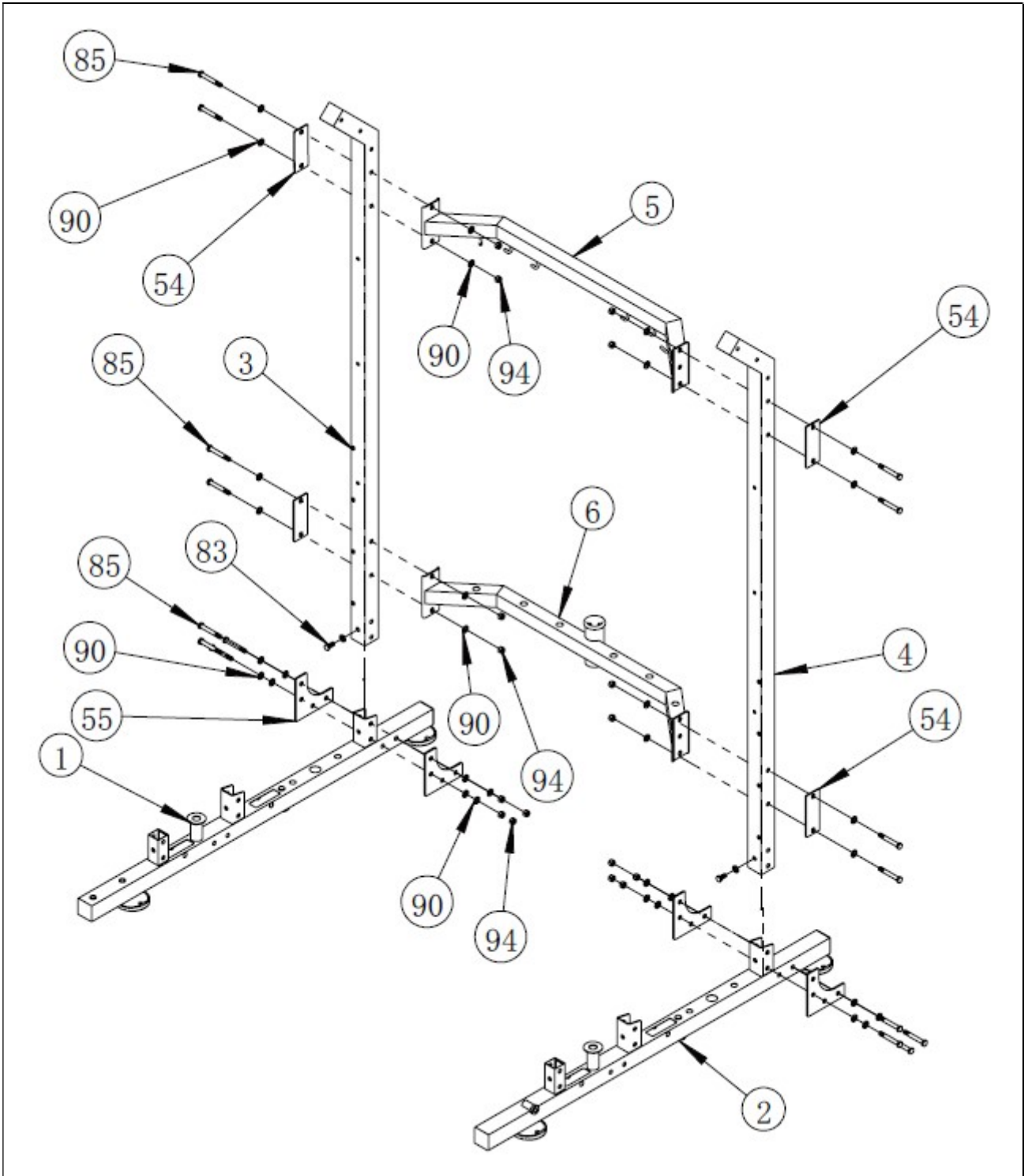

Obr. 2

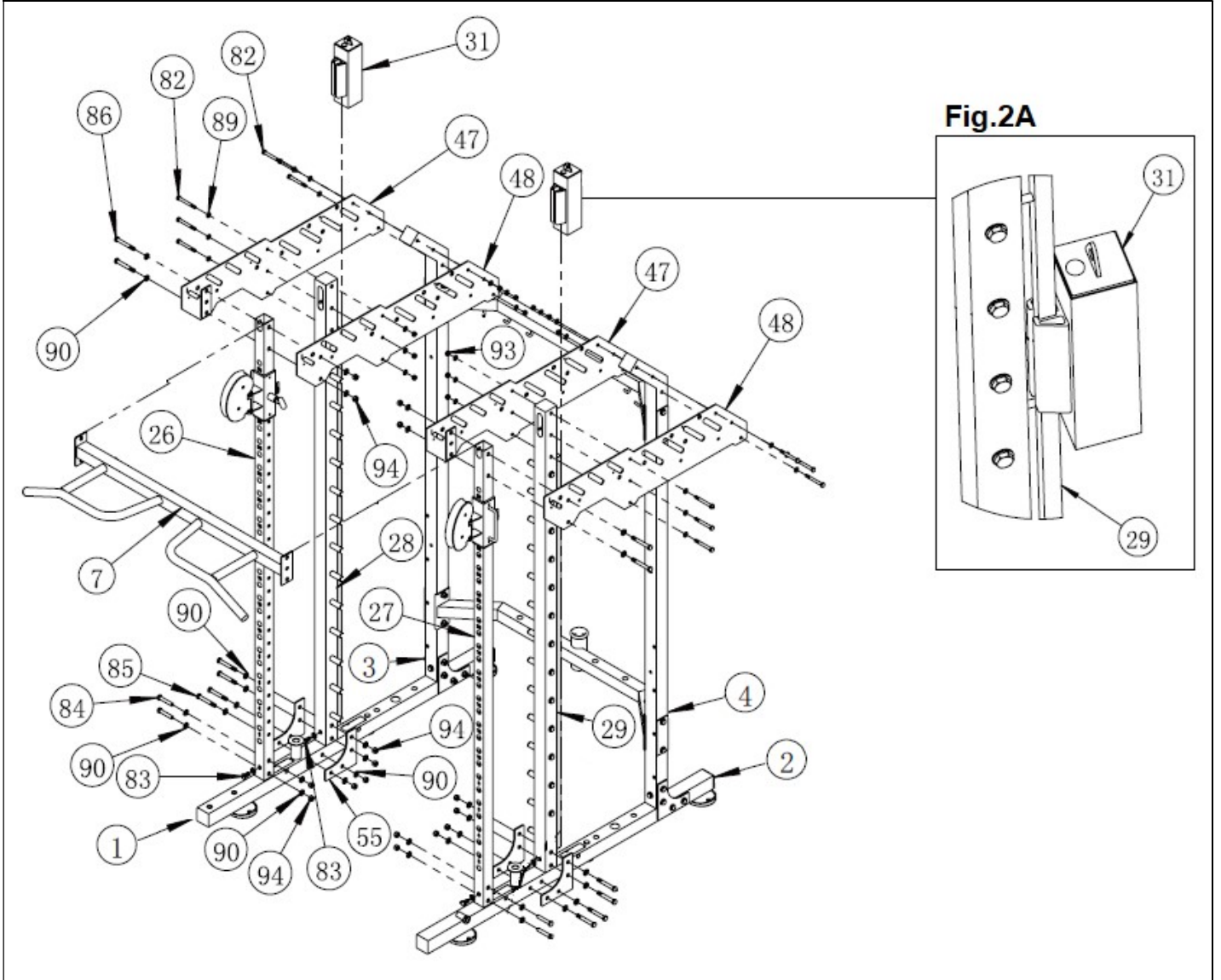



Obr. 3 – G145

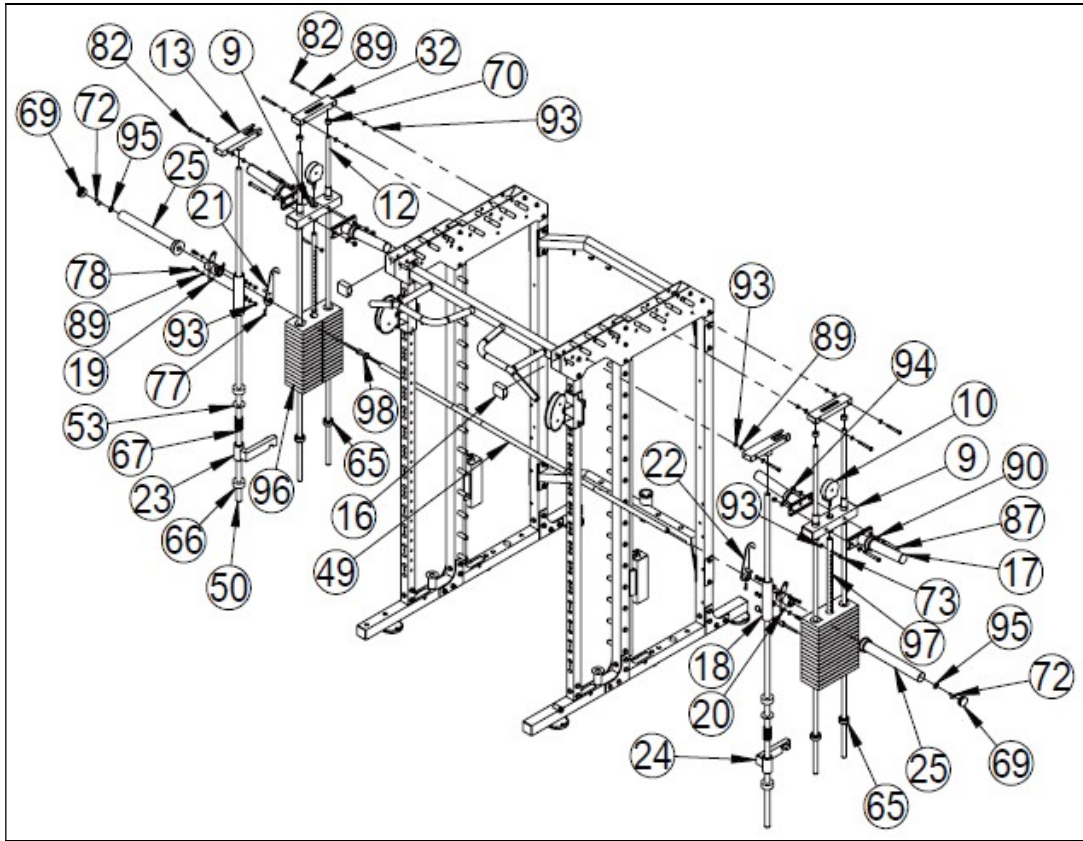

Obr. 3A – G145

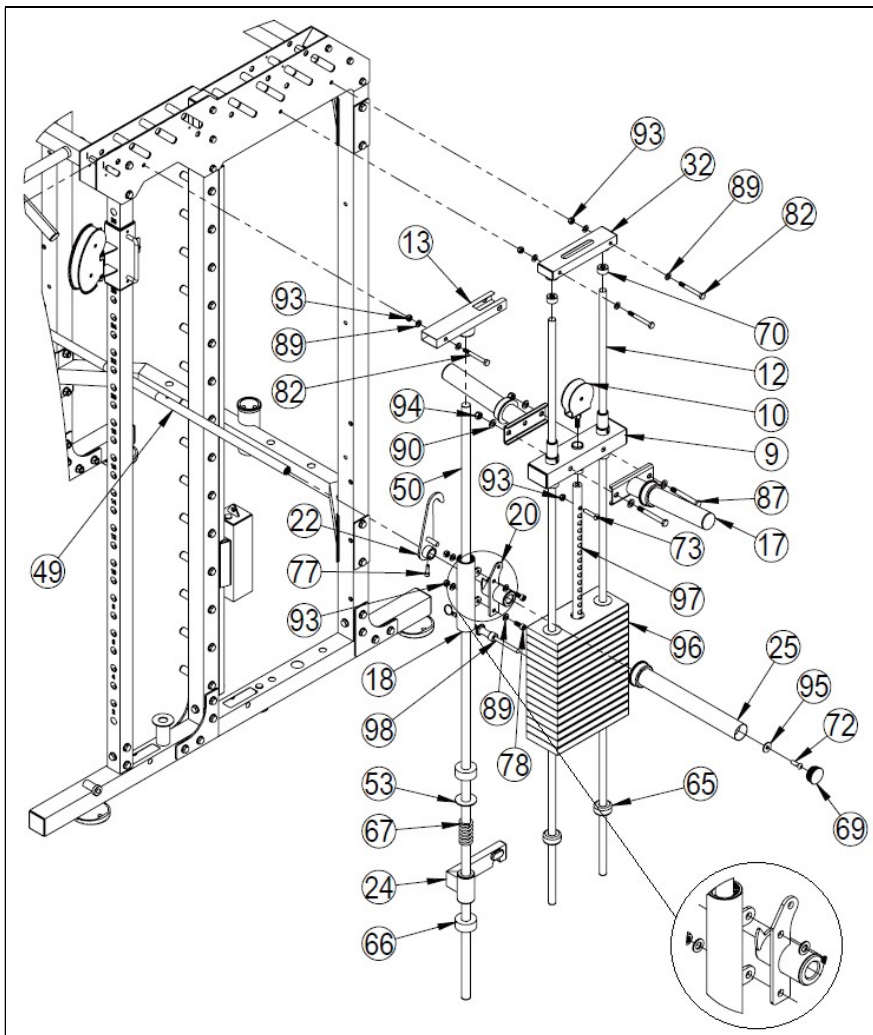

Obr. 3 – G140

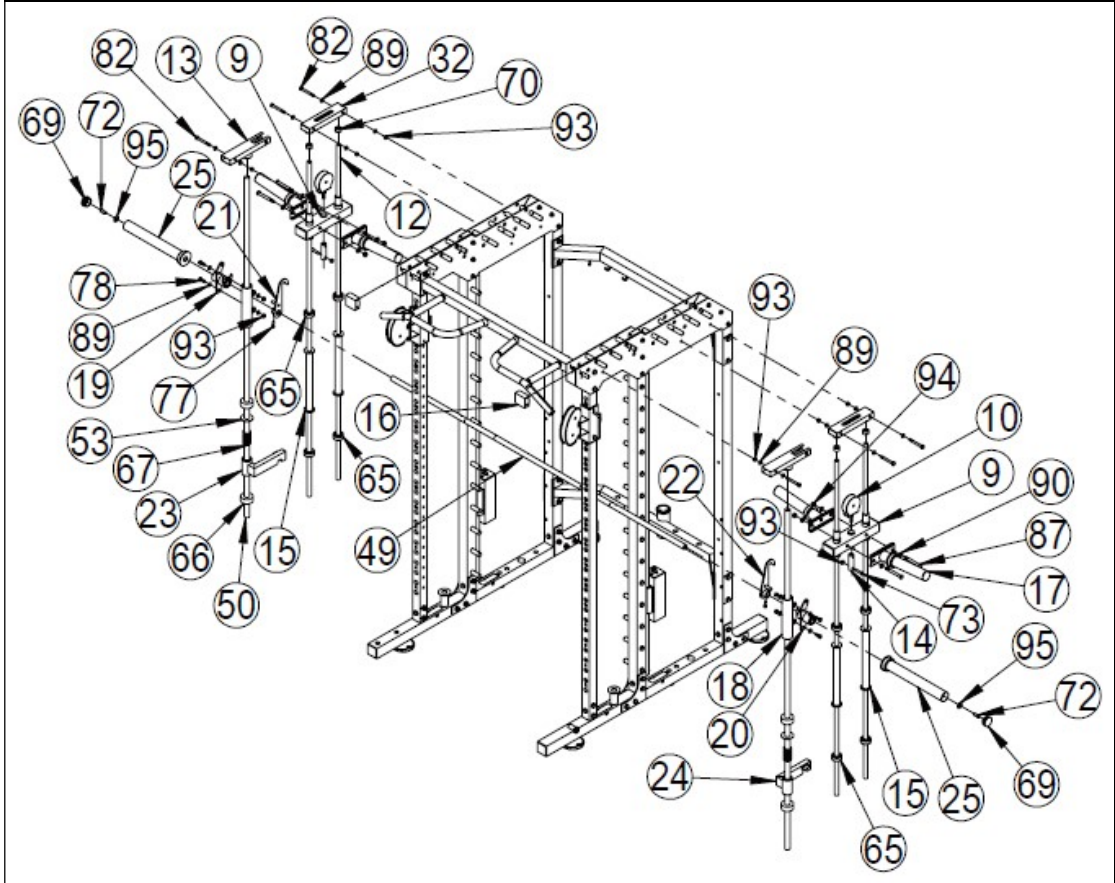

Obr. 3A – G140

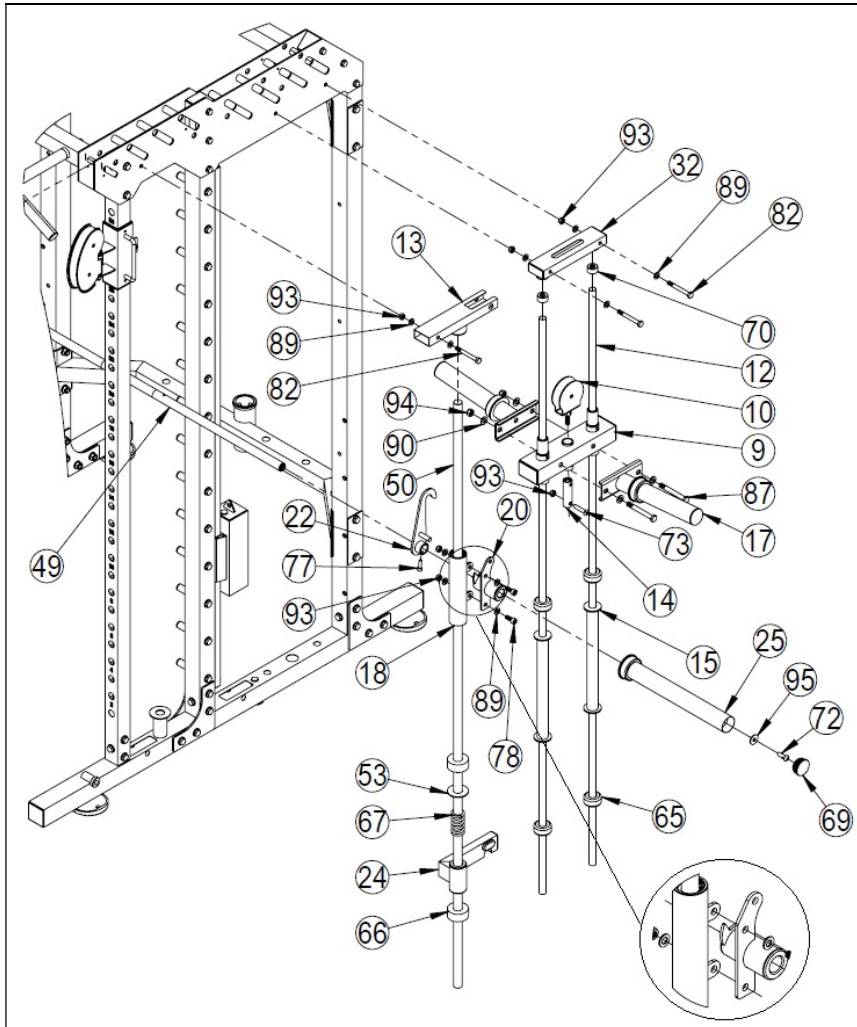

Obr. 4

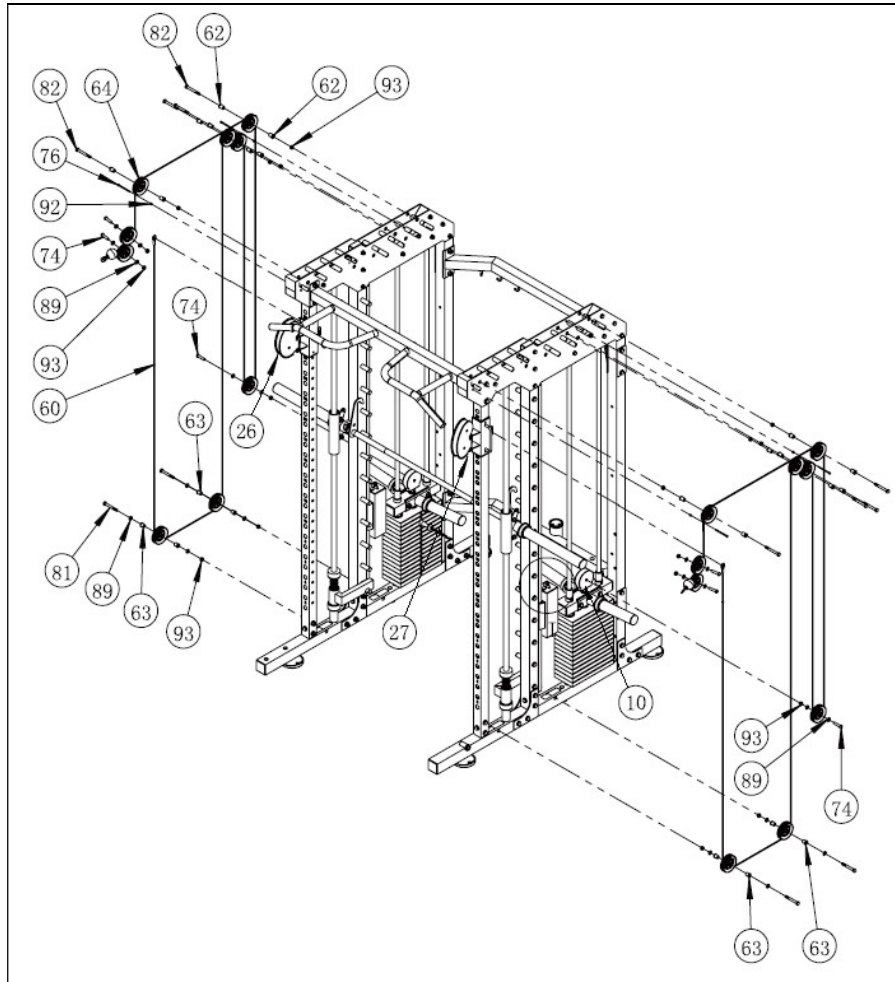

Obr. 4A

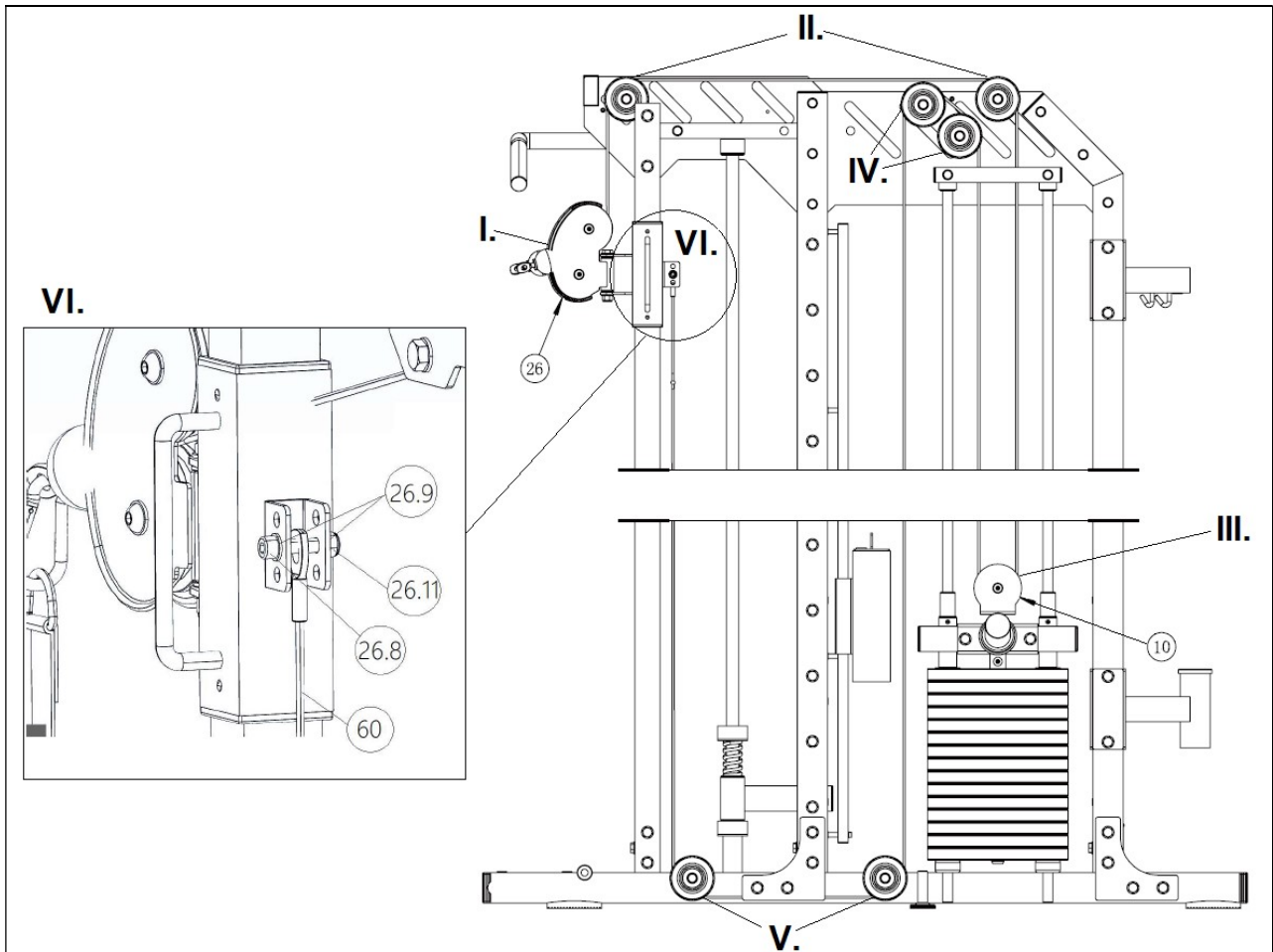

Obr. 5

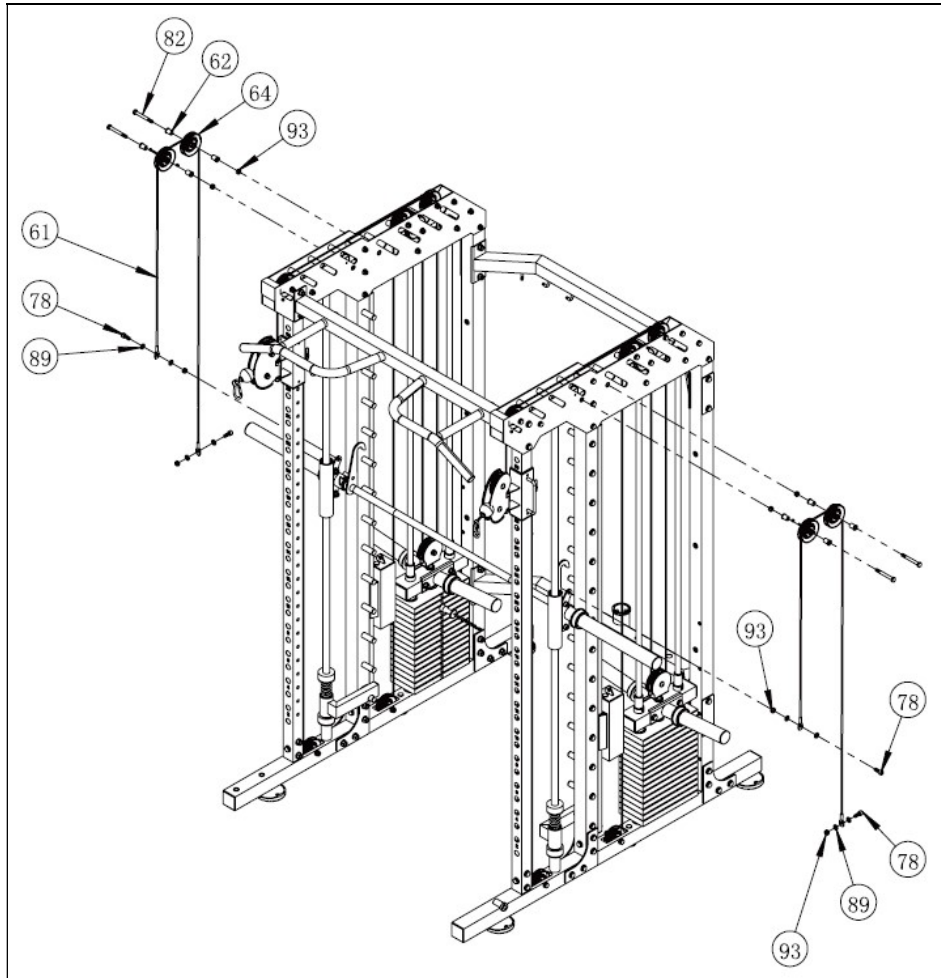

Obr. 5A

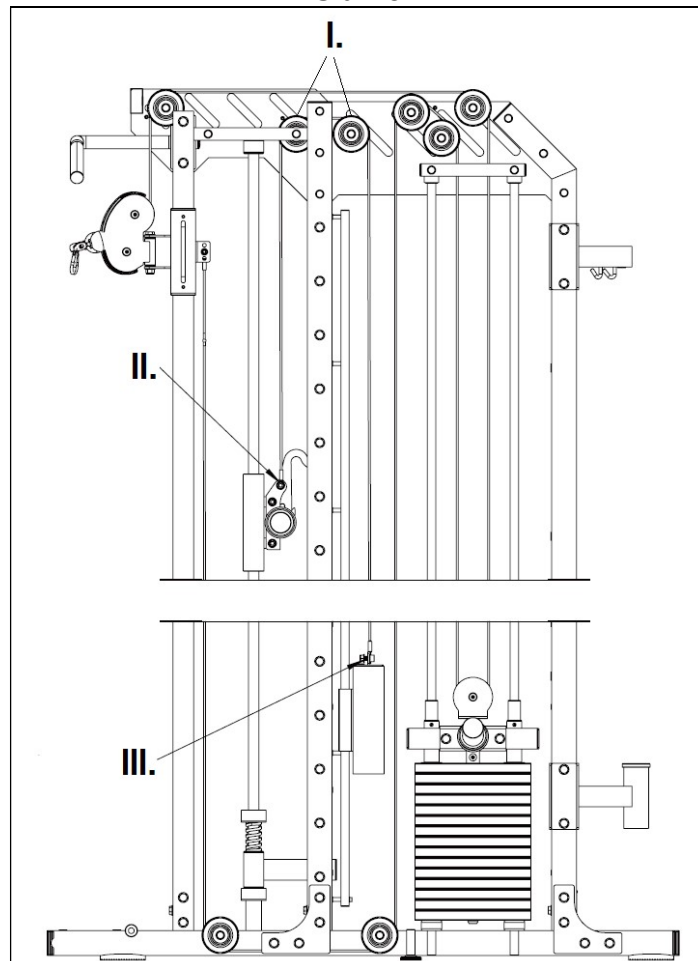

Obr. 6

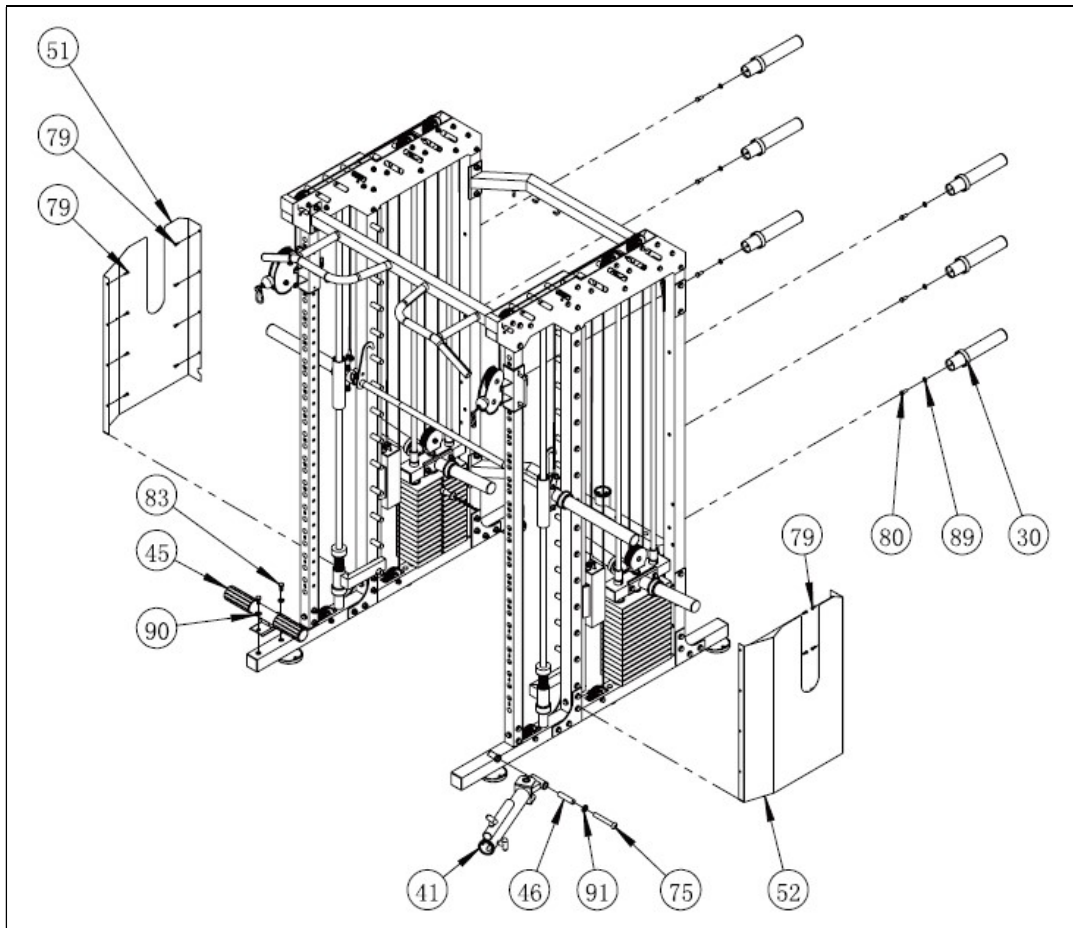

Obr. 7

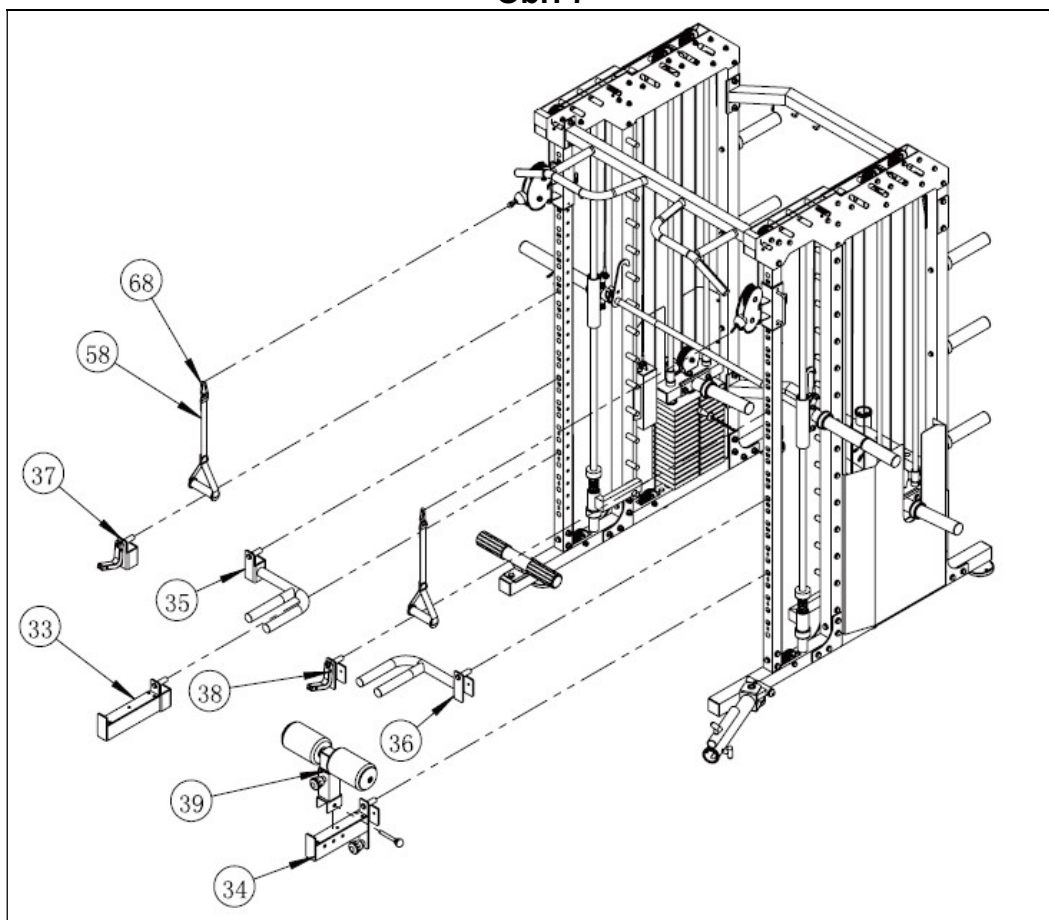

Obr. 8

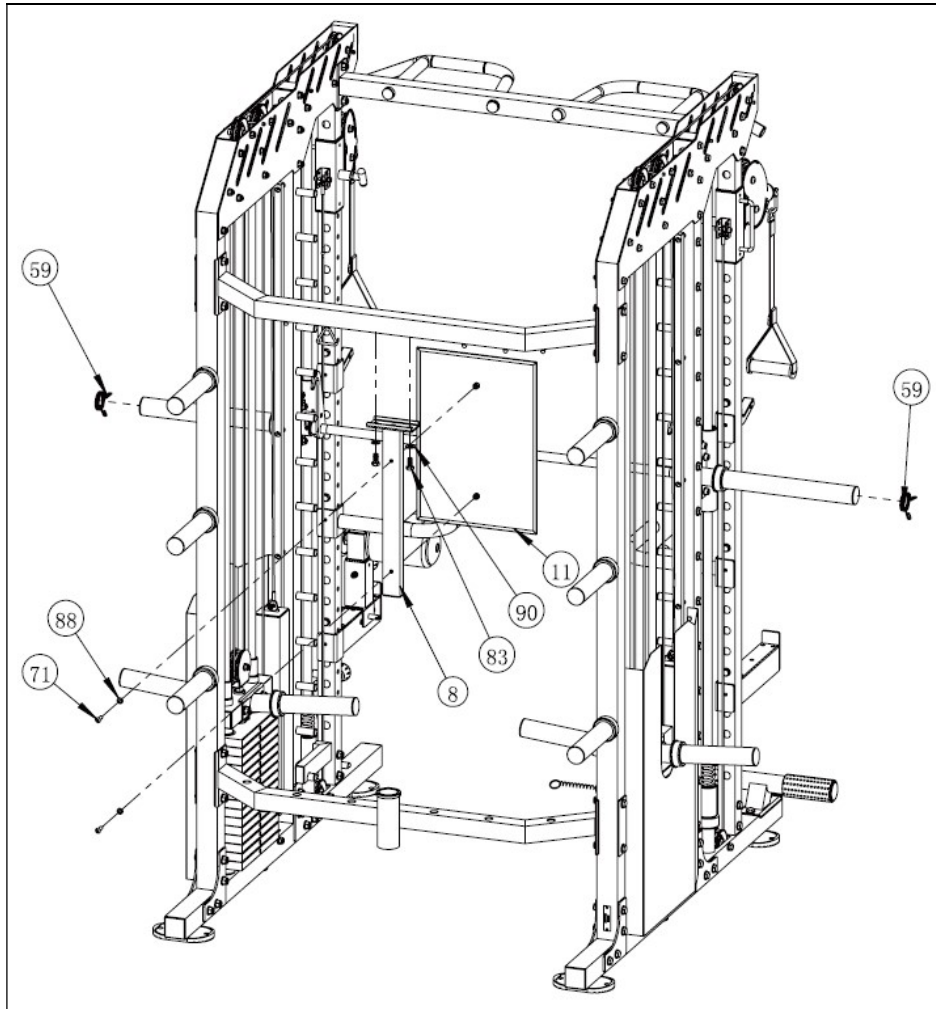

Obr. 9

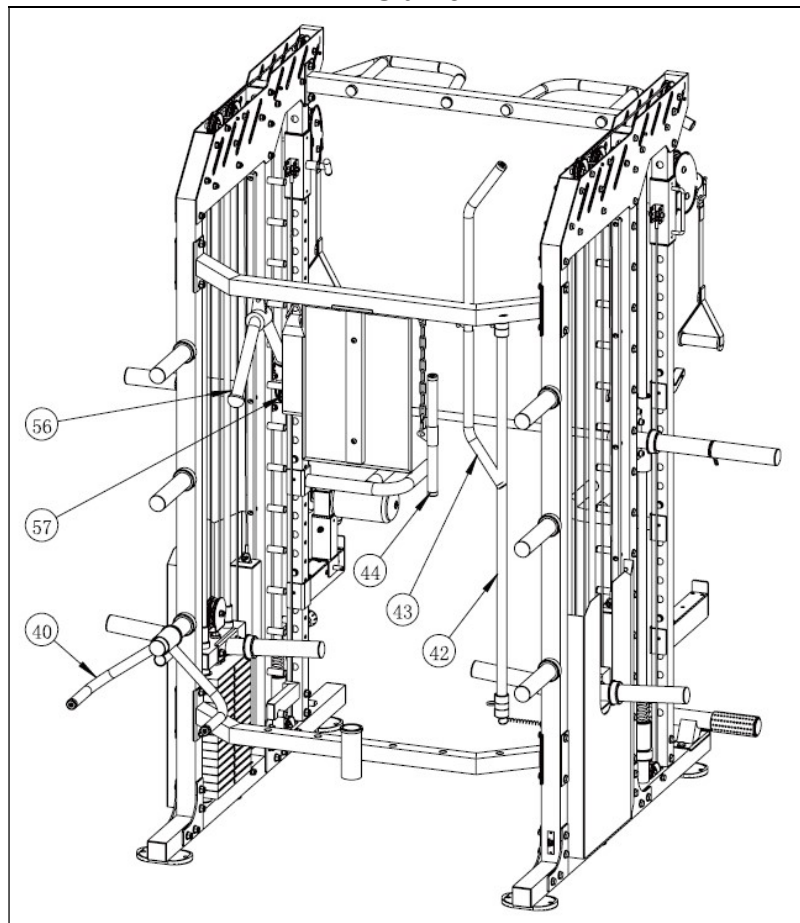

## VŠEOBECNÉ POKYNY

Pečlivě si prostudujte pokyny obsažené v této příručce. Naleznete zde důležité informace o montáži, bezpečnosti a používání posilovací stanice.

Dodržujte následující doporučení:

1 Nenechávejte děti nebo zvířata v blízkosti zařízení bez dozoru.

2 Na zařízení může v daném čase cvičit pouze jedna osoba.

3 Cvičte na doporučené úrovni, nepřepínejte se. Pokud pocítíte bolest nebo nevolnost, okamžitě přestaňte cvičit a poradte se se svým lékařem.

4 Umístěte jednotku na rovný povrch tak, aby kolem dokola zůstal alespoň 1 m volného prostoru. Jednotku použijte na pevném a rovném povrchu, nepoužívejte jej venku.

5 Udržujte ruce mimo dosah pohyblivých částí.

6 Používejte vhodný oděv a obuv, dbejte na zavázané tkaničky.

7 Nikdy nepoužívejte příslušenství, které není doporučeno výrobcem.

8 Kolem jednotky nepokládejte žádné ostré předměty.

9 Nedovolte dětem nebo osobám s postižením používat zařízení bez dohledu kvalifikované osoby.

10 Před cvičením se protáhněte.

11 Zvolte vhodné závaží podle vaší fyzické kondice.

12 Zařízení nepoužívejte, pokud je poškozené nebo neúplné.

13 Je doporučeno cvičit pod dohledem.

14 Tato jednotka byla navržena pro poloprofesionální použití. Maximální hmotnost uživatele je 130 kg.

**Upozornění: Než začnete trénovat, poradte se se svým lékařem. Tato rada je zvláště důležitá pro osoby starší 35 let nebo pro osoby se zdravotními problémy.**

**Pokyny uschovejte pro případné budoucí využití.**

## ÚDRŽBA

1 Pohyblivé části pravidelně mažte. Alespoň jednou ročně.

2 Před prvním použitím zkontrolujte, zda jsou všechny části utaženy a zda jednotka funguje správně.

3 K čištění zařízení použijte vlhký hadřík. Nepoužívejte rozpouštědla.

## MONTÁŽNÍ POKYNY

Vyjměte jednotku z krabice a ujistěte se, že tam jsou všechny díly, viz obr. A a obr. B.

1.- Připevněte levou (3) a pravou (4) svislou trubku k levé (1) a pravé (2) spodní nosné trubce, umístěním upevňovacích desek (55) a pomocí šroubů (83), (85), podložky (90) a matice (94), obr. 1.

Připevněte horní (5) a spodní (6) zadní trubku k levé (3) a pravé (4) vertikální trubce umístěním upevňovacích desek (54) a pomocí šroubů (85), podložek (90) a matic. (94), obr. 1.

**POZNÁMKA: Šrouby neutahujte pevně.**

2.- Připevněte levý (28) a pravý (29) sloupek k levé (1) a pravé (2) spodní nosné trubce, umístěte upevňovací desky (55) a pomocí šroubů (83), (85) podložky (90) a matice (94), obr. 2.

Připevněte levou (26) a pravou (27) trubku posuvného rámu k levé (1) a pravé (2) spodní nosné trubce pomocí šroubů (83), (84), podložek (90) a matic (94). Obr. 2.

Připevněte podpěry závaží (31) k levému (28) a pravému (29) sloupku, obr.2A.

Připevněte vnitřní desky (47) a (48) k levé (3) a pravé (4) svolslé trubce a k levému (28) a pravému (29) sloupku pomocí šroubů (82), podložek (89) a matic. (93).

Připevněte vnitřní desky (47) a (48) a horní rám (7) k levé (26) a pravé (27) trubce posuvného rámu pomocí šroubů (86), podložek (90) a matic (94). Obr. 2.

**Pevně utáhněte všechny šrouby z prvního a druhého kroku.**

3.- G145

Umístěte nárazníkové podložky (65) na vodící tyče (12) a tyče umístěte na levou (1) a pravou (2) spodní nosnou trubku, obr. 3. Připevněte závaží (96). Připojte kladku (10), držák disku (17) a tyč nesoucí závaží

(97) k hornímu závaží (9) pomocí šroubů (73), (87), podložek (89), (90) a matic. (94). Obr. 3.

(98) Umístěte sestavu horního závaží na tyče (12), připevněte pouzdra (70) a horní držák (32) k hornímu konci tyčí (12) pomocí šroubů (82), podložek (89) a matic (93). Umístěte vodící lištu (50) na pravou spodní trubku (2), umístěte tlumení (66), bezpečnostní sestavu (24), pružinu (67), pouzdro (53), druhé tlumení (66), podpěru (18) a horní podpěru (13) pomocí šroubu (82), podložky (89) a matice (93), obr. 3A. Provedte stejný postup s vodící lištou (50) na levé spodní nosné trubce (1). Připevněte hák pravé tyče (22) a pravou podpěru (20) k pravé straně tyče, obr. 3A, pomocí šroubu (77). Provedte stejný postup na levé straně s hákem (21) a levou podpěrrou (19). Umístěte sestavu na podpěru (18) pomocí šroubů (78), podložek (89) a matic (93), obr. 3. Umístěte držáky disků (25) na konce lišty (49) pomocí šroubů (72) a podložek (95) a umístěte zátky (69), obr. 3. Vložte zátky (16) do horní podpěry. Umístěte kolík pro volbu závaží (97), obr. 3.

### 3.- G140.-

Umístěte nárazníkové podložky (65) na vodící tyče (12) a tyče umístěte na levou (1) a pravou (2) spodní nosnou trubku, obr. 3.

Připevněte kladku (10), držák disku (17) a podpěru (14) k hornímu závaží (9) pomocí šroubů (73), (87), podložek (89), (90) a matic (94). Obr. 3.

Umístěte sestavu horního závaží na tyče (12), připevněte pouzdra (70) a horní držák (32) k hornímu konci tyčí (12) pomocí šroubů (82), podložek (89) a matic (93).

Umístěte vodící lištu (50) na pravou spodní trubku (2), umístěte tlumení (66), bezpečnostní sestavu (24), pružinu (67), pouzdro (53), druhé tlumení (66), podpěru (18) a horní podpěru (13) pomocí šroubu (82), podložky (89) a matice (93), obr. 3A. Provedte stejný postup s vodící lištou (50) na levé spodní nosné trubce (1).

Připevněte hák pravé tyče (22) a pravou podpěru (20) k pravé straně tyče, obr. 3A, pomocí šroubu (77). Provedte stejný postup s levou stranou a hákem (21) a levou podpěrou (19).

Umístěte sestavu na podpěru (18) pomocí šroubů (78), podložek (89) a matic (93), obr. 3.

Umístěte držáky disků (25) na konce lišty (49) pomocí šroubů (72) a podložek (95) a umístěte zátky (69), obr. 3.

Vložte zátky (16) do horní podpěry.

4.- Připevněte kladky (64) a lanko (60) k levé (26) a pravé (27) podpěře kladek pomocí šroubů (74), (85), podložek (89) a matic (93). 4, Obr. 4A, I.

Umístěte lanko (60), kladky (64) na konce horního rámu pomocí šroubů (82), průchodek (62) a matic (93), obr. 4, obr. 4A, II.

Připevněte kladky (64) a lanko (60) k podpěrám kladek (10) pomocí šroubů (74), podložek (89) a matic (93), obr. 4, obr. 4A, III.

Připevněte lanko (60), kladky (64) k horní konstrukci pomocí šroubů (82), průchodek (62) a matic (93), obr. 4, obr. 4A, IV.

Připevněte lanko (60), kladky (64) k levé (1) a pravé (2) spodní trubce pomocí šroubů (81), průchodek (63) a matic (93), obr. 4, obr. 4A, V.

Připevněte konec lanka k levé (26) a pravé (27) podpěře kladek s kluzným ložiskem pomocí šroubu (26.8), podložek (26.9) a matic (26.11), obr. 4, obr. 4A, VI.

5.- Připevněte kladky (64) a lanko (61) k hornímu rámu pomocí šroubů (82), pouzder (62) a matic (93), obr. 5, obr. 5, I. Připevněte konec lanka (61) k levé (19) a pravé (20) podpěře pomocí šroubů (78), podložek (89) a matic (93), obr. 5, obr. 5, II. Druhý konec kabelu (61) připevněte k podpěře (31) pomocí šroubů (78), podložek (89) a matic (93), obr.5, obr.5, III

6.- Připevněte držáky disků (30) k levé (3) a pravé (4) kolmé trubce pomocí šroubů (80) a podložek (89), obr. 6.

Připevněte levý (51) a pravý (52) kryt pomocí šroubů (79), obr. 6.

Umístěte podpěru (41) na pravou spodní trubku (2) pomocí pouzdra (46), šroubu (75) a podložky (91), obr. 6.

Umístěte opěrku nohou (45) na pravou spodní trubku (1) pomocí šroubů (83) a podložek (90), obr. 6.

7.- Připevněte levý (33) a pravý (34) nárazník, levou (35) a pravou (36) tyč, levý (37) a pravý (38) držák na levou (26) a pravou (27) tyč, obr. 7.

Odstraňte aretační šroub (39) z opěrky kolena (39), umístěte opěrku na pravý nárazník (34) a nasadte zpět aretační šroub, obr. 7. Připevněte rukojeti (58) ke kabelu (60), obr. 7.

8.- Připevněte nosný rám (8) k horní zadní trubce (5) pomocí šroubů (83) a podložek (90), obr. 8. Připevněte desku (11) k držáku (8) pomocí šroubů (71) a podložek (88), obr. 8.

Připevněte spony (59) k držákům disku (25), obr. 8.

9.- Umístěte tyče (42), (43), (44) a madla (56), (57) na horní zadní trubku (5), obr. 9.

Umístěte veslovací rukojeť (40) na zadní držák disku, obr. 9.

Pokud máte jakékoli dotazy, obraťte se na naši technickou asistenční službu (viz poslední strana příručky).

**BH FITNESS SI VYHRAZUJE PRÁVO ZMĚNIT SPECIFIKACE SVÝCH VÝROBKŮ BEZ PŘEDCHOZÍHO UPOZORNĚNÍ.**



(ESP) TABLA DE EJERCICIOS  
 (GB) EXERCISE CHART  
 (FR) TABLEAU D'EXERCICES  
 (DE) ÜBUNGSTABELLE  
 (IT) TABELLA DEGLI ESERCIZI

ARMS

SHOULDERS



KNEELING CRUNCH

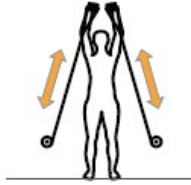

SHOULDER PRESS

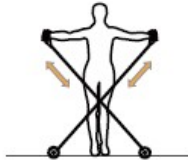

LATERAL RAISE

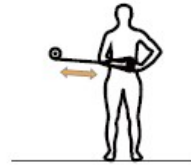

INTERNAL ROTATION

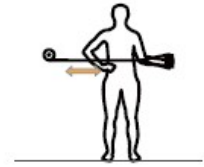

EXTERNAL ROTATION

CHEST

CORE



INCLINE PRESS



CHEST PRESS



DECLINE PRESS



PEC FLY



DEAD LIFT



TRICEPS PRESS DOWN

BACK



HIGH ROW

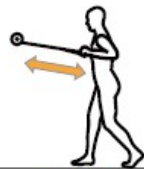

MID ROW



REAR DELTOID



CHIN-UPS

LOWER BODY



SQUAT



LUNGE



LUNGE-DECELERATING

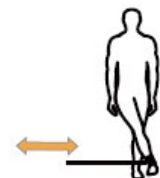

HIP ADDUCTION

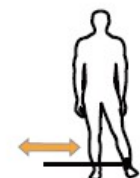

HIP ABDUCTION



HIP FLEXION

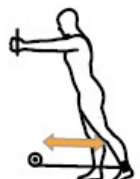

HIP EXTENSION



SQUAT



LEG EXTENSION



LEG CURL

# G140-G145

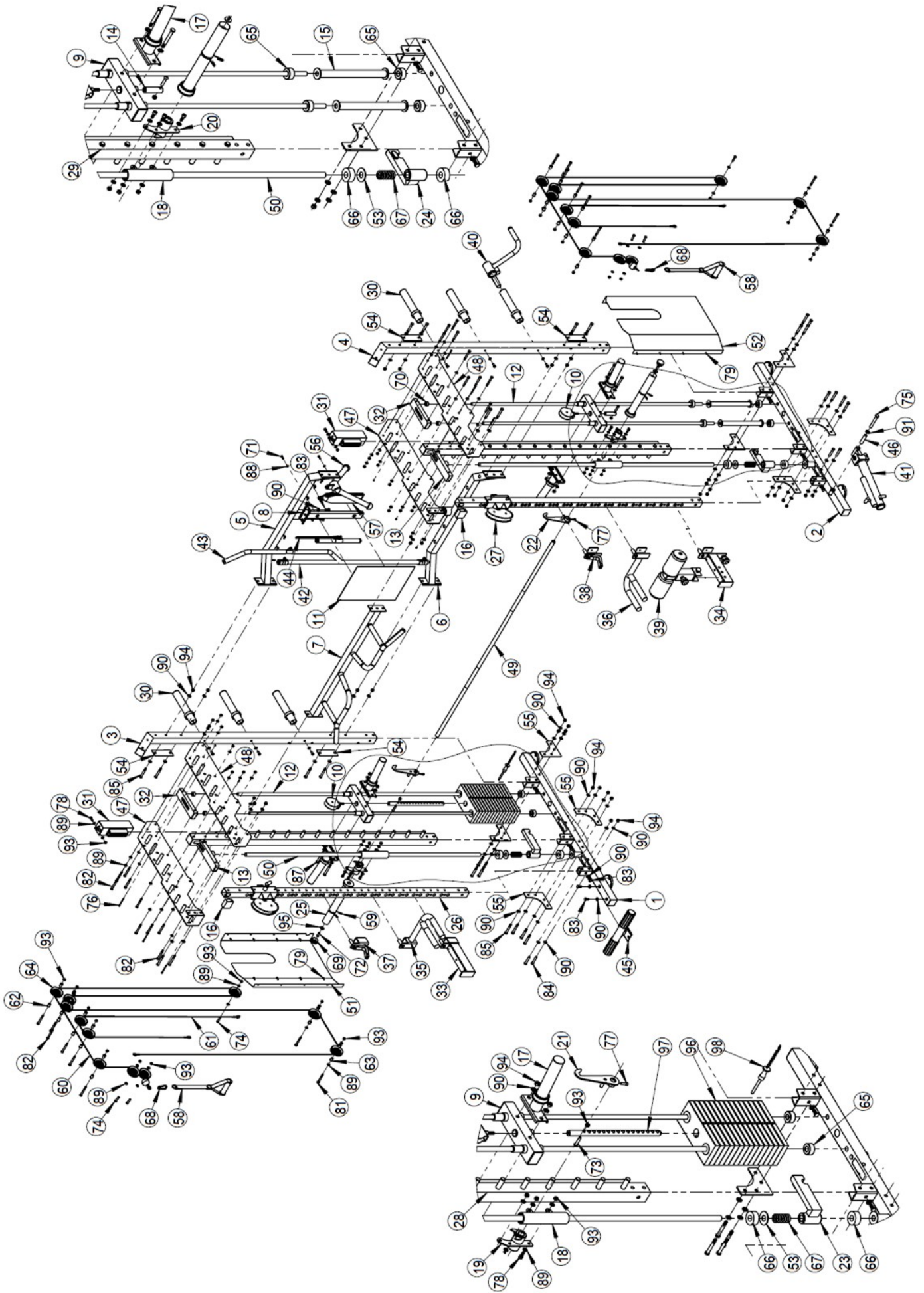

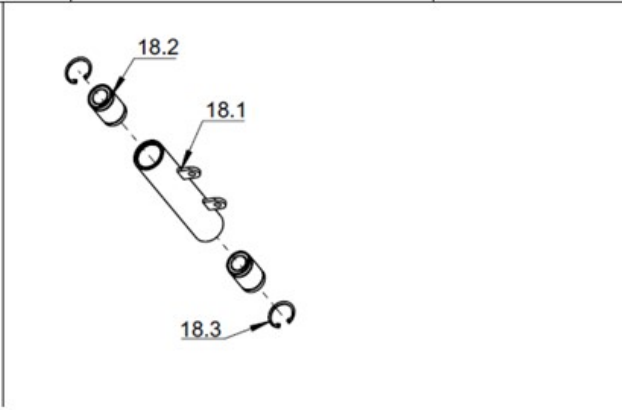
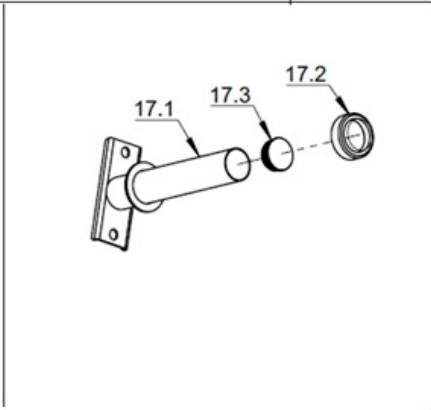
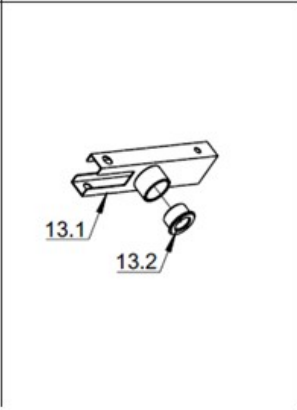
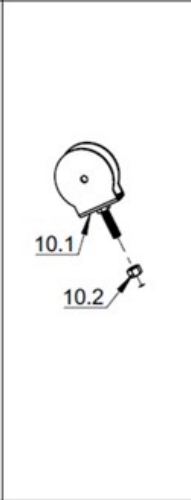
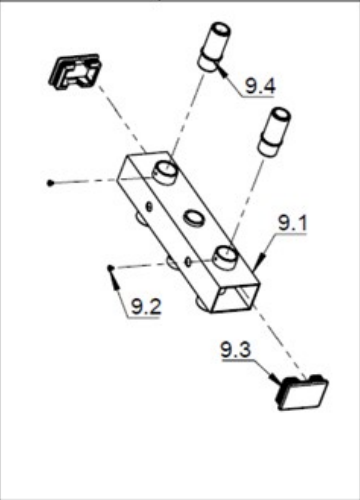
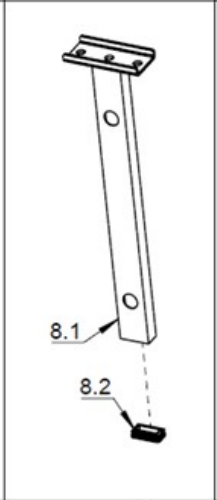
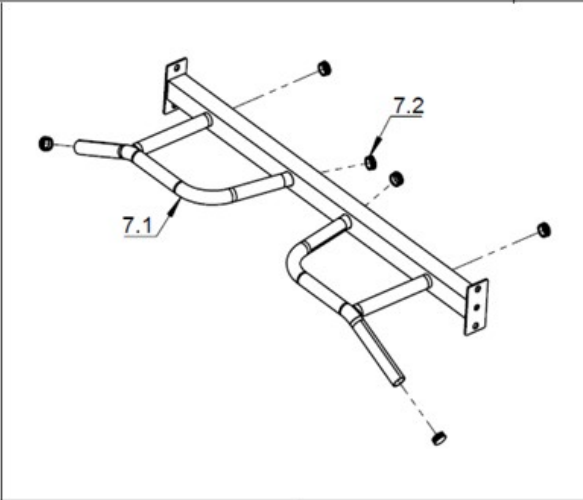
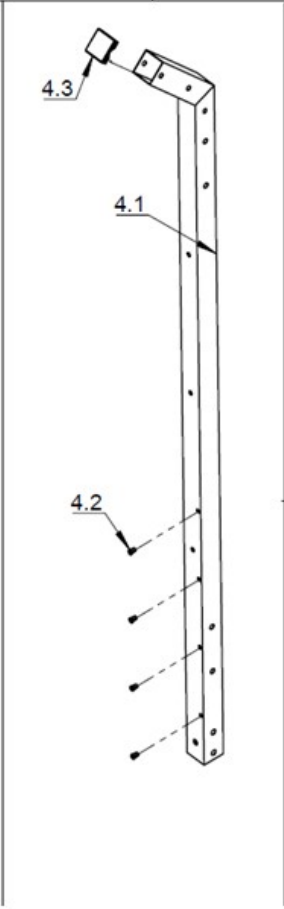
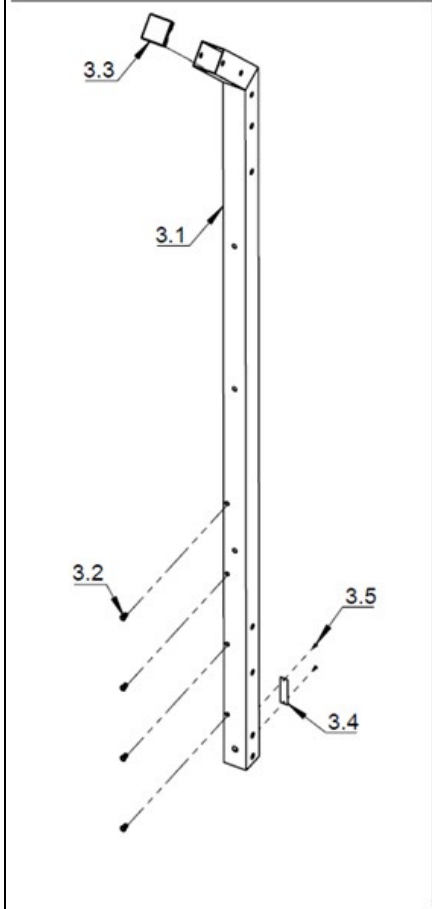
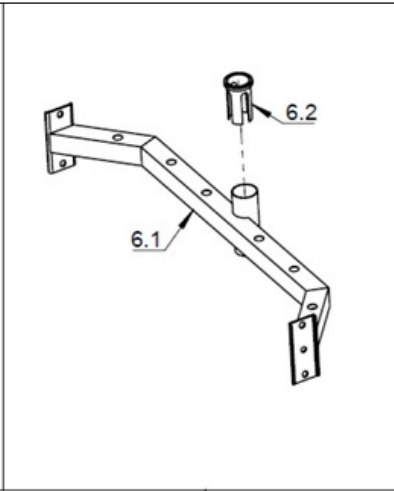
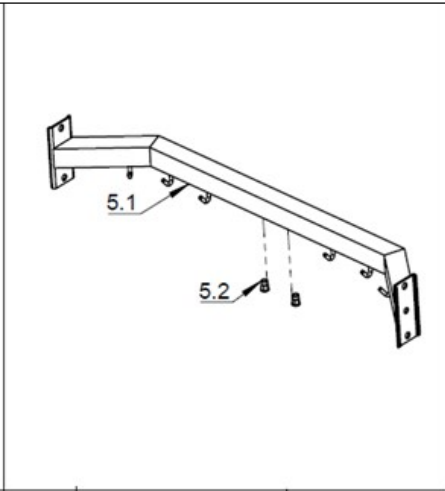
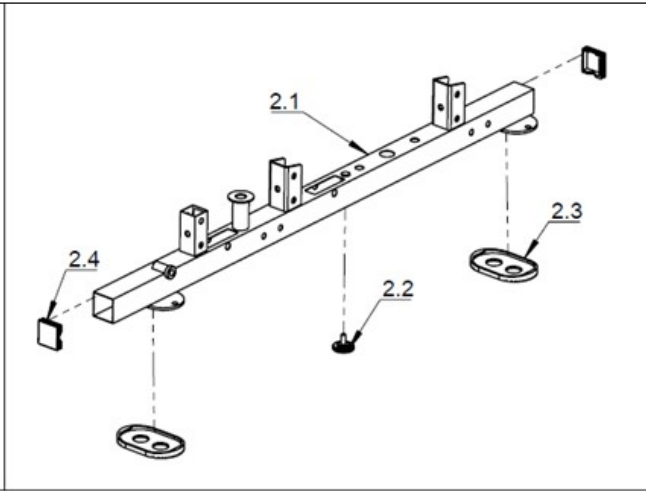
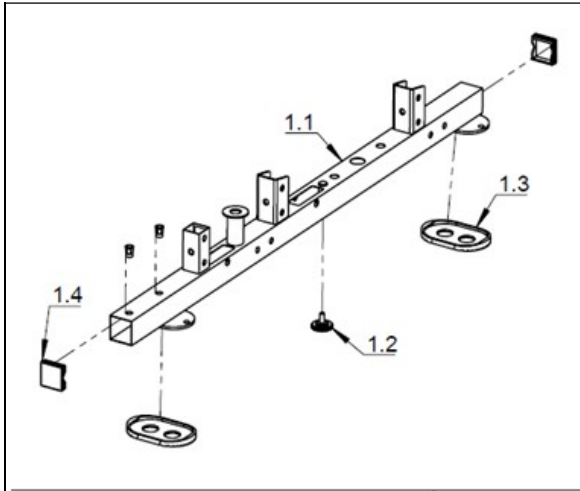

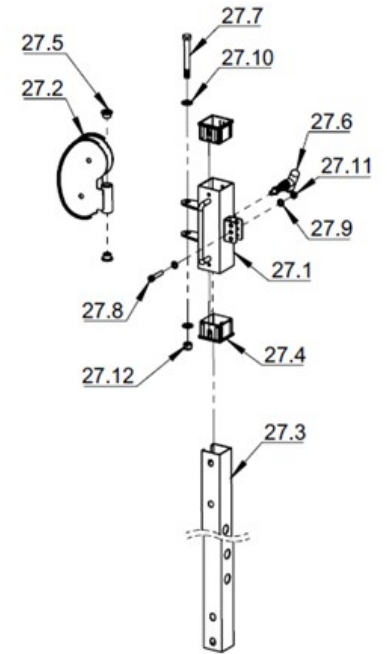
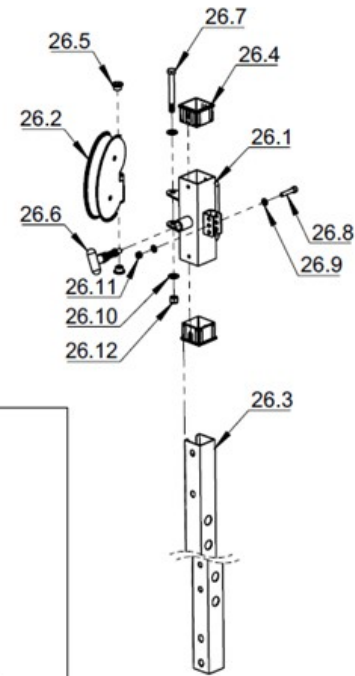
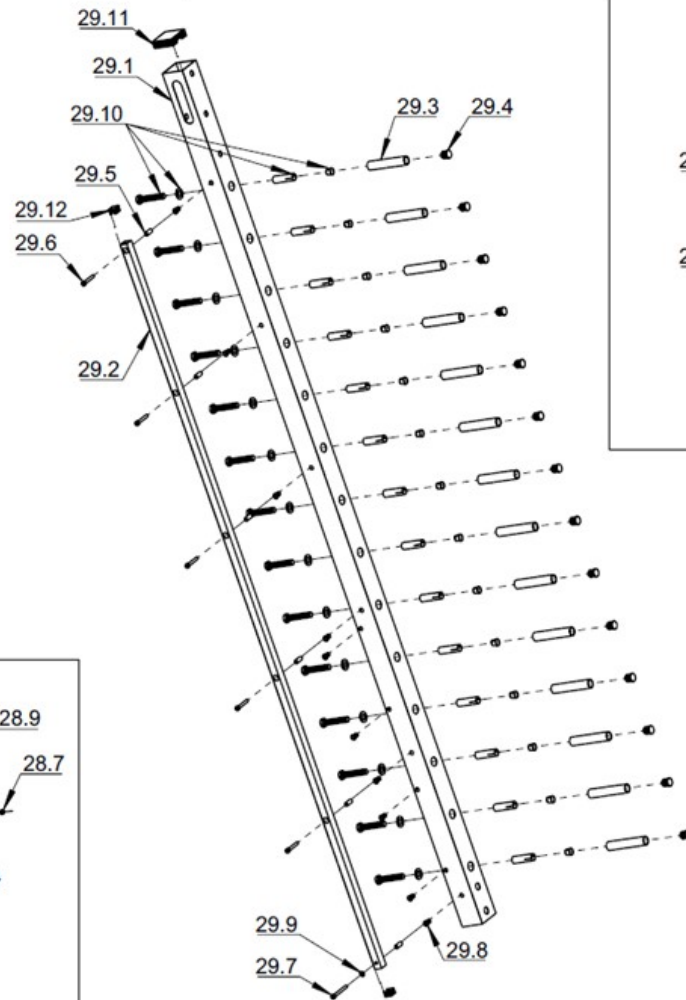
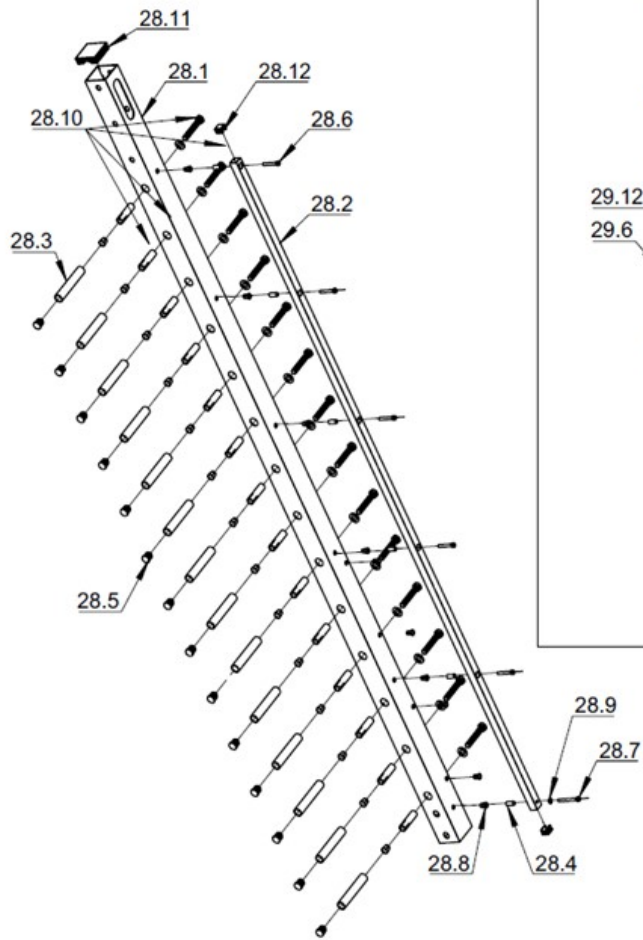
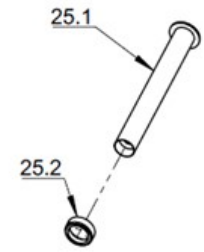
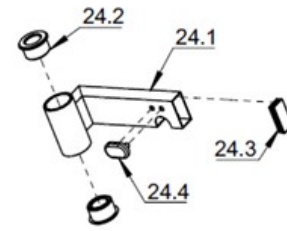
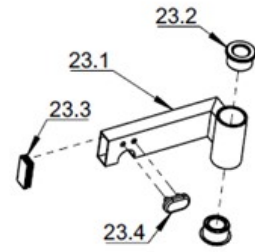
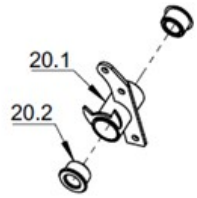
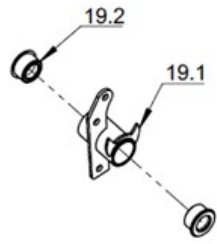

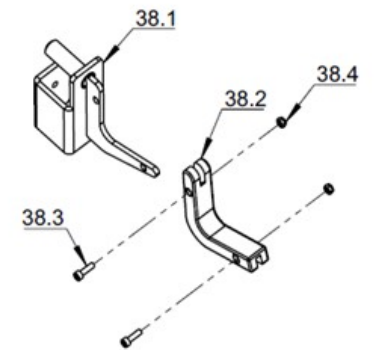
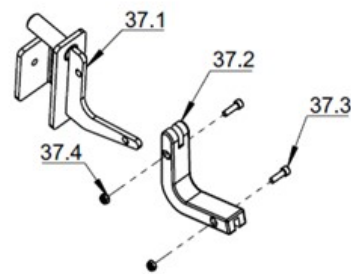
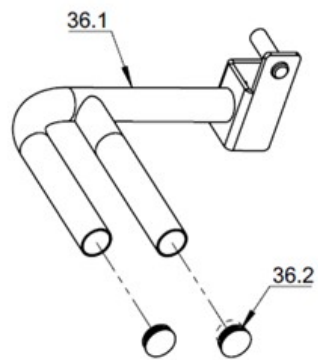
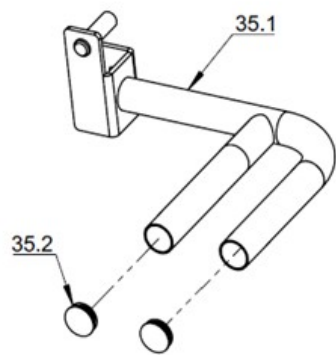
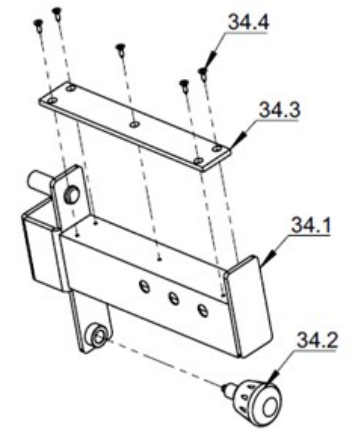
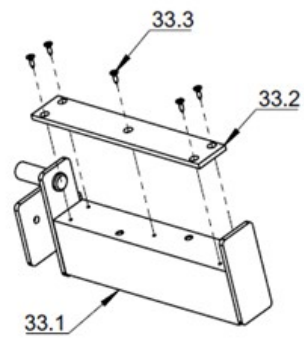
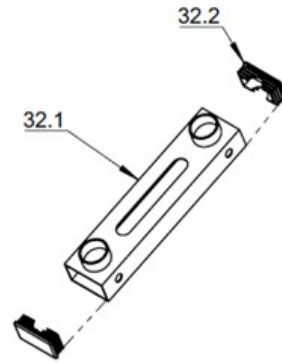
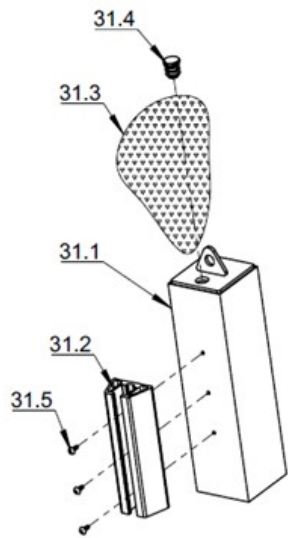
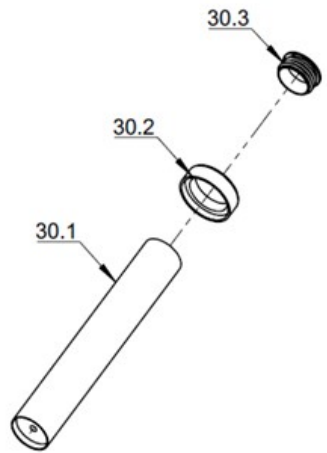

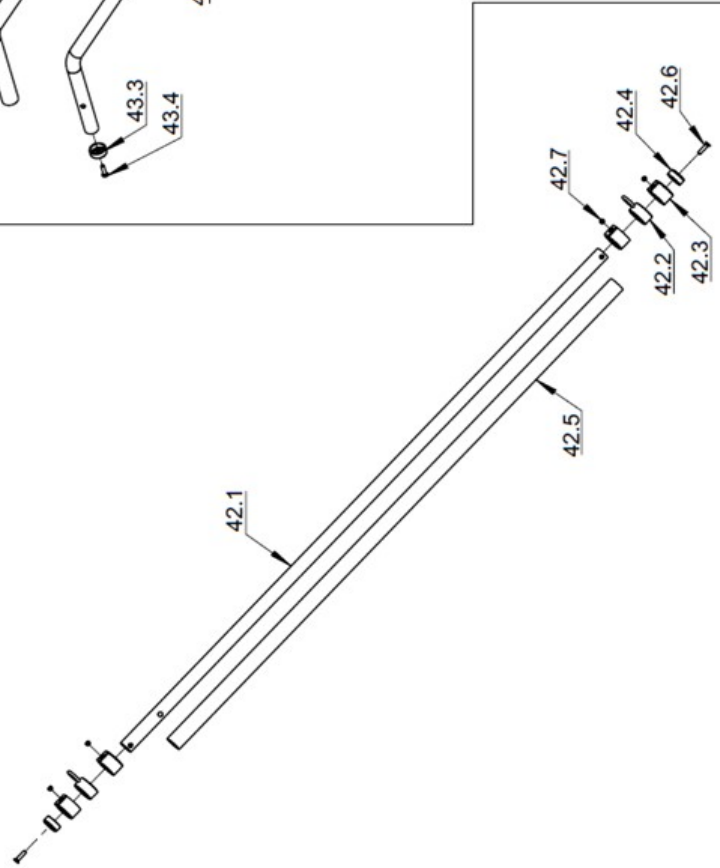
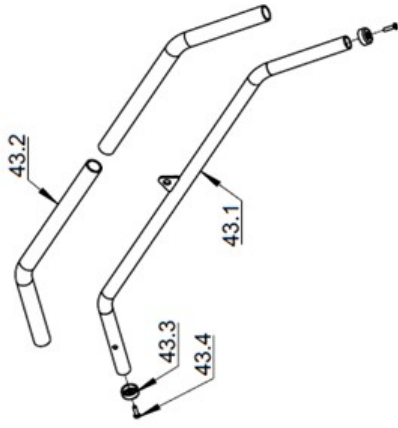
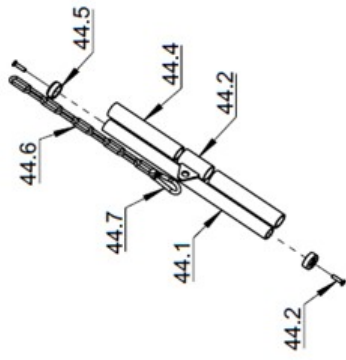
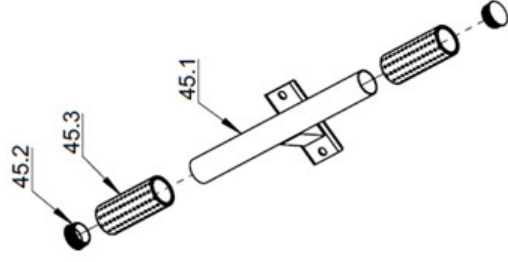
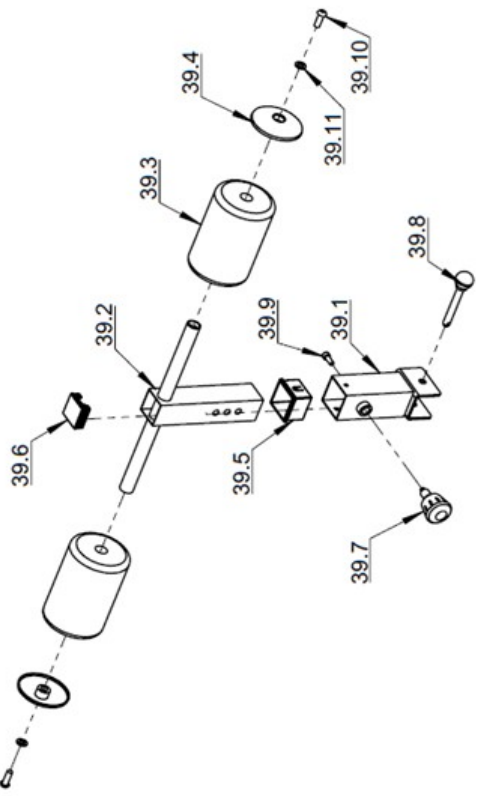
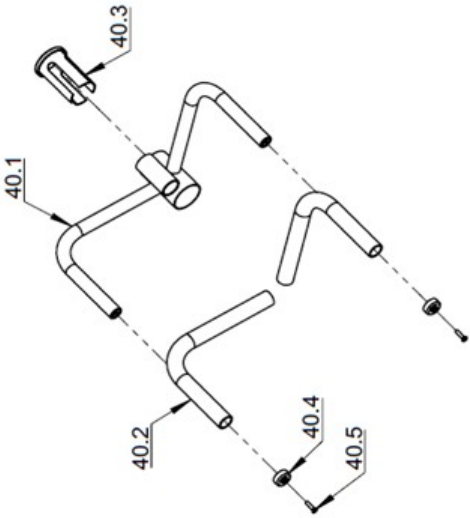
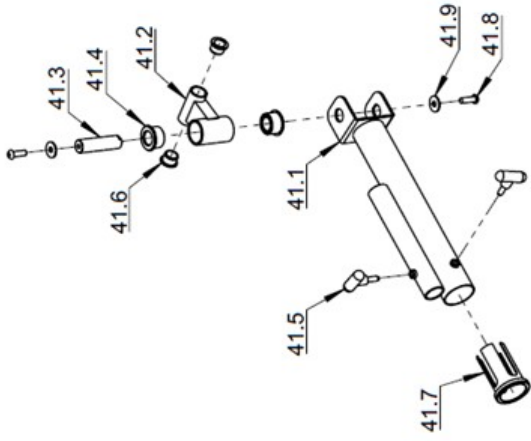

Dovozce a distributor pro  
Českou a Slovenskou republiku  
Trinteco spol. s r.o.  
Na Strži 2102/61a,  
140 00 Praha 4 – Krč  
IČ: 052 54 175  
DIČ:CZ05254175



Dovozce a distributor pro Českou a Slovenskou republiku  
Trinteco spol. s r.o.  
Na Strži 2102/61a, 140 00 Praha 4 – Krč  
IČ: 052 54 175 DIČ:CZ05254175  
Email: [info@trinteco.cz](mailto:info@trinteco.cz)  
Telefon: +420 725 552 257